



Powerlink Microelectronics

PL3325C

Accurate CV/CC Primary Side PWM Power Switch

Product Description

PL3325C is a series of high efficiency Primary Side Regulator and highly integrated PWM Power Switch for sub 12W AC/DC power supply applications. It simplifies conventional CC/CV charger/adaptor designs by eliminating the opto-coupler and secondary control circuitry. Very tight output voltage and current regulation is realized as shown in the Fig.1 below.

During operation, multi-mode operations are utilized to achieve low standby power, high efficiency and audio & noise free. The integrated Power MOSFET could reduce external components and system cost.

PL3325C also offers rich protection features including Cycle-by-Cycle peak current limiting, UVLO, OVP. The switch continues attempting start-up until the fault condition is removed. Every restart is a soft start.

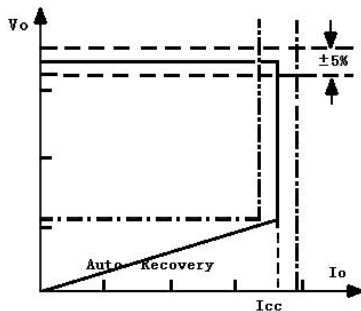
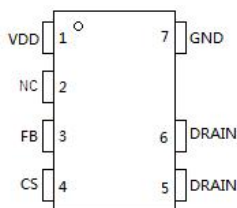
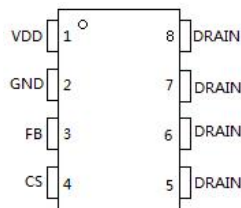

Fig.1. Typical CC/CV Curve

Pin Configuration



PL3325CS/D/H



PL3325CE

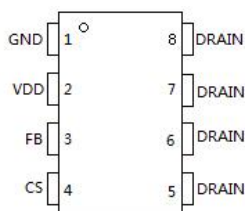

PL3325CF

Key Features

- Built-in Integrated Power MOSFET
- +/-5% Constant Voltage Regulation
- Accurate Constant Current Regulation at Universal AC input
- Eliminates Opto-coupler and all Secondary CV/CC Control Circuitry
- Built-in Line Compensation for Tighter CC Regulation
- Built-in Compensation for Transformer Inductance Tolerances
- Adjustable Output Cable Compensation
- Adaptive Multi-mode PWM/PFM Control for Improving Efficiency
- Low Start-up Current
- Built-in Leading Edge Blanking (LEB)
- Cycle-by-Cycle Current Limiting
- VDD Under Voltage Lockout with Hysteresis(UVLO)
- Built-in Output Overvoltage Protection
- Good dynamic response

Applications

- Cell/Cordless Phone Charger
- PDA/Portable Audio Device Charger
- Small Power Adaptor/Charger
- Standby Supply for Consumer Electronics



1 Overview

PL3325C is a primary side CC/CV regulator designed for high performance offline Switch Mode Power Supplies with minimal external components. The device is integrated high voltage power switching regulators which combines an avalanche rugged Sense FET with a primary side control block.

PL3325C is designed for sub 12W AC/DC applications. And it provides accurate current/voltage without requiring the opto-coupler and the secondary control circuitry. It also eliminates the need of loop compensation circuitry while maintaining stability. thus, very tight output voltage and current regulation is achieved.

PL3325C's multi-mode operations are utilized to achieve low standby power, high efficiency and audio & noise free. in CC mode as well at

large load condition, it operations in PFM mode, while at light load or medium load, PL3325C works in PWM with frequency reduction. This green-mode function assists the power supply meeting the power conservation requirements.

A complete set of integrated protection functions allows PL3325C to protect against all fault conditions including Cycle-by-Cycle peak current limiting, VDD UVLO, OVP . The switch continues attempting start-up until the fault condition is removed.

PL3325CS is offered in SOP7 package.

PL3325CD/H is offered in DIP7 package.

PL3325CE is offered in SOP8 package.

PL3325CF is offered in SOP8 package.

2 Features

- Built-in Integrated Power MOSFET
- +/-5% Constant Voltage Regulation
- Accurate Constant Current Regulation at Universal AC input
- Eliminates Opto-coupler and all Secondary CV/CC Control Circuitry
- Built-in Line Compensation for Tighter CC Regulation
- Built-in Compensation for Transformer Inductance Tolerances
- Adjustable Output Cable Compensation
- Adaptive Multi-mode PWM/PFM Control for Improving Efficiency
- Low Start-up Current
- LEB
- OCP
- OVP
- Good dynamic response
- UVLO

3 Pin Diagrams

The pin map is shown as below .

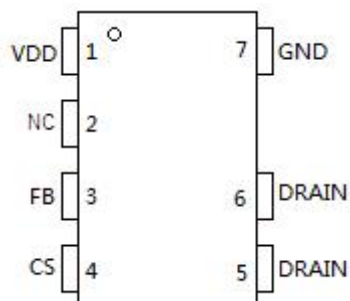

PL3325CS (SOP7)/ PL3325CD/H(DIP7)

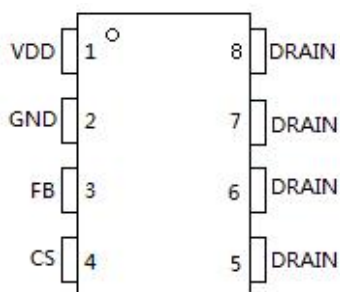

PL3325CE(SOP8)

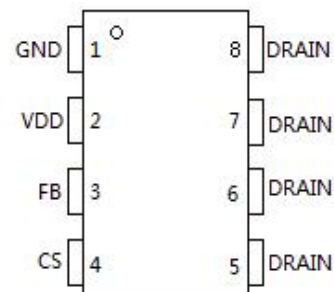

PL3325CF(SOP8)

4 Pin Description

Pin	Description
VDD	IC power supply.
NC	Floating pin.
FB	Through two dividing resistors connecting to the bias winding, this pin could get the information of output to realize the CV/CC regulation.
CS	This pin could detect the primary current by the voltage of sensing resistor connected from CS to GND.
DRAIN	HV MOSFET Drain Pin. The Drain pin is connected to the primary lead of the transformer.
GND	IC ground.

5 Absolute Maximum Ratings

Absolute maximum ratings are the parameter values or ranges which can cause permanent damage and affect device reliability if exceeded.

Parameter	Symbol	Value	Units
DC Supply Voltage Range	VDD	-0.3 to 30	V
CS Input	CS	-0.3 to 5	V
FB Input	FB	-0.3 to 5	V
Maximum Junction Temperature	Tjmax	150	°C
Storage Temperature	Tsto	-55 to 150	°C
Lead Temperature(Soldering,10secs)	Tlea	260	°C

Note: These are stress ratings only. Stress beyond these limits may cause permanent damage to the device. Functional operation of the device at these or any conditions beyond those indicated under Recommended Operating Conditions is not implied. Exposure to absolute maximum rated conditions for extended periods of time may affect device reliability.

6 Recommended Operating Conditions

Parameter	Min	Max	Unit
Operating Temperature	-20	+105	°C

7 Block Diagram

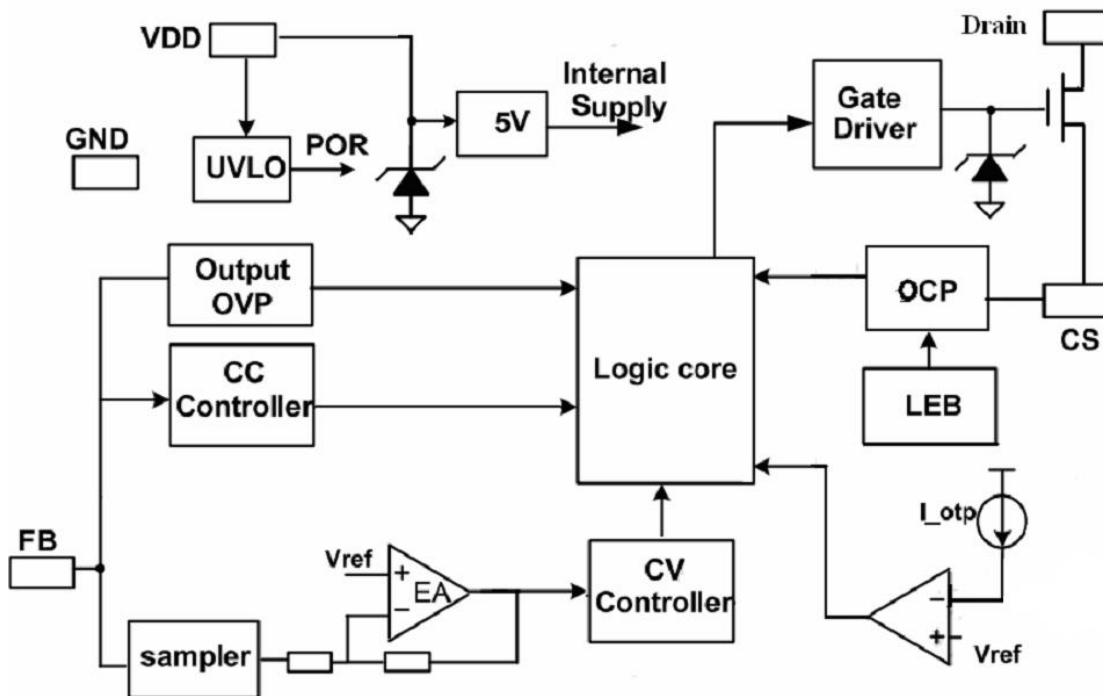

8 Electrical Characteristics

(VDD =16V, TA = 25°C, unless otherwise specified)

Parameter	Symbol	Test Conditions	Min	Typ	Max	Unit
Supply Voltage (VDD) Section						
Standby Current	I _{DD_sd}	VDD=16V		5	20	uA
Operating Current	I _{DD_op}	Operating supply current FB=2V, CS=0V, VDD=20V		1	1.5	mA
VDD Under Voltage Enter Threshold	UVLO(ON)	VDD falling	6	7		V
VDD Under Voltage Exit Threshold	UVLO(OFF)	VDD rising		15	17	V
VDD over voltage threshold	VDD_OVP			27		V
Current Sense Section						
Turn on LEB Time	TLEB			300		ns
Over Current Threshold	Vocp			500		mV
CC/CV Control Section						
Reference Voltage for EA	Vref_EA		2.465	2.5	2.535	V
Minimum off time	Toff_min			2		us
Minimum frequency	Fosc_min			550		Hz
Maximum frequency	Fosc_max		120			kHz
Maximum cable compensation current	Icable_max			48		uA
Output over voltage threshold	Vfb_ovp			3		V
Over Temperature Protection						
Protection trigger point	T_otp			150		°C
Power Mosfet Section (PL3325CS/D/E/F)						
MOSFET Drain-Source Breakdown Voltage	BVdss		650			V
On Resistance	Rdson	Id=1A/VGS=10V		4.8		Ω
Power Mosfet Section (PL3325CH)						
MOSFET Drain-Source Breakdown Voltage	BVdss		900			V
On Resistance	Rdson	Id=1A/VGS=10V		5.5		Ω

9 Application

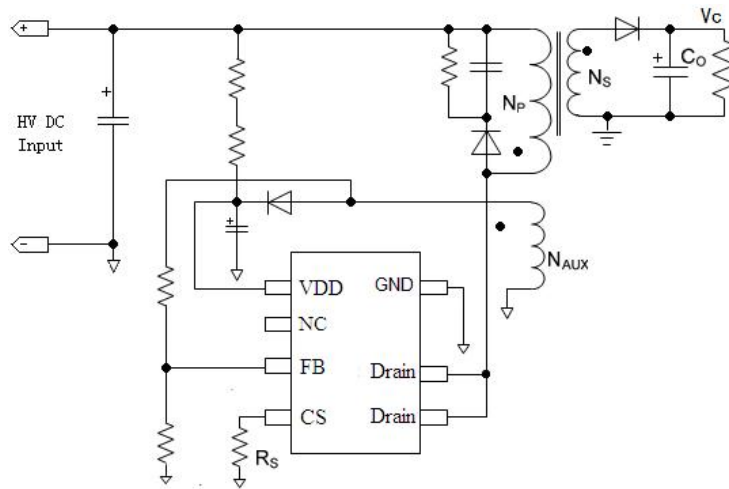

PL3325CS/D/H

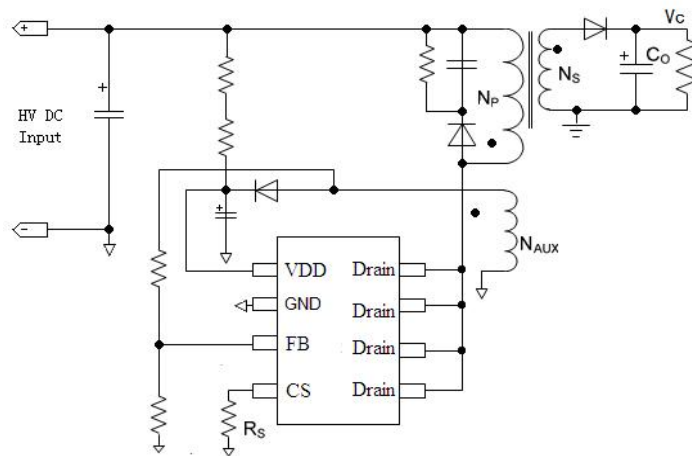

PL3325CE

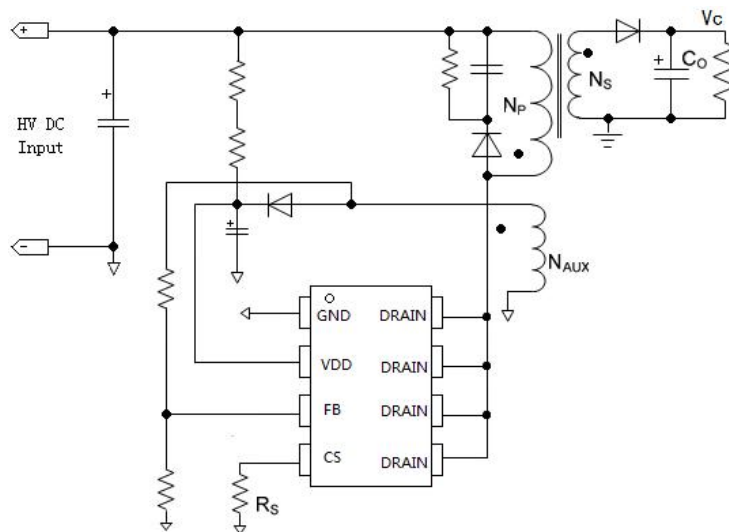

PL3325CF

Application Notes

PL3325C provides a cost effective solution for low power adaptor/charger applications. The innovative CV and CC control can remove the need for secondary feedback circuitry while achieving excellent CV/CC for much more strict requirements.

9.1 Startup & Operating Current

PL3325C has very slight startup current, thus the larger value startup resistor and smaller VDD capacitor can be used to minimize the power loss in application.

The operating current of PL3325C is as low as 1mA. Together with 'Multi-mode' control features we could get high efficiency especially in light load.

9.2 Under Voltage Lockout (UVLO)

An UVLO detector is implemented in it to detect the voltage on the VDD pin. It would assure the supply voltage enough to turn on the PWM controller and further to drive the power mos. a hysteresis is built in to prevent the shutdown from the voltage dip during startup. The turn-on and turn-off threshold level are set at 15 V and 7 V, typically.

9.3 Realization of CV/CC

The CV/CC control is based on the system working in DCM.

In the DCM fly-back converter, the output voltage can be sensed via the auxiliary winding. During MOSFET turn-on time, the current in the primary winding ramps up. When MOSFET turns off, the primary current transfers to the secondary at the amplitude of

$$I_{Spk} = \frac{N_P}{N_S} \cdot I_{Ppk} \quad (1)$$

I_{Ppk} is the current in the primary winding at the point MOSFET turns off.

Through coupling between the secondary and

auxiliary winding the output voltage is given by

$$V_o = \frac{N_S \cdot V_{aux}}{N_{aux}} - \Delta V \quad (2)$$

Where V_{aux} is the voltage of the auxiliary winding and ΔV indicates the drop voltage of the output diode.

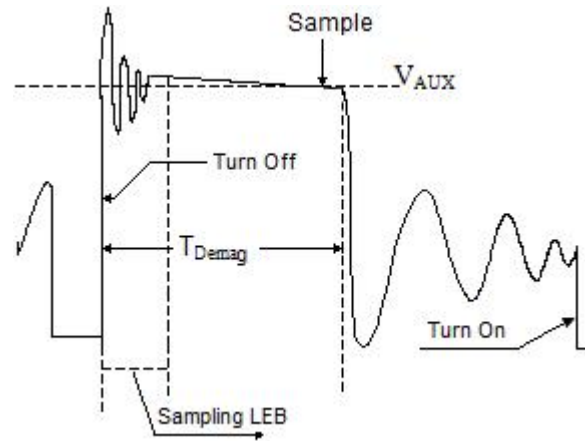

Fig.2. Voltage of Auxiliary-winding Waveform

Via a resistor divider connected between the auxiliary winding and FB, the auxiliary voltage is sampled based on the internal timing control. Through the built-in error amplifier the sampled voltage could be regulated at a preset level, thus constant output voltage can be achieved.

During the CC mode of operation PL3325C will regulate the output current at a constant level regardless of the output voltage, while avoiding continuous conduction mode.

9.4 Adjustable CC Point and Output Power

In application of less equal than 12W, we could change the R_s to get different CC points and the maximum output power only using one model. The larger R_s , the smaller CC point is, and the smaller output power becomes.

9.5 Switching Frequency and Lm Tolerance Compensation

The system load condition and the operation

mode decide the switching frequency of PL3325C. The maximum switching frequency is set by system design. In DCM assuming the efficiency to 100%, the output power is given by

$$P_o = \frac{1}{2} L_m f_{sw} I_{Ppk}^2 = V_o \bullet I_o \quad (3)$$

Where L_m indicates the inductance of the primary winding and I_{Ppk} is the peak current of the primary winding.

Refer to the equation 3, the change of L_m results in the change of P_o and the constant output current in the CC mode. The tolerance of L_m will make CC worse in mass production. To smooth it away, we use an internal L_m compensation circuit to correct the offset of inductance.

Whatever L_m is changed to, the CC point is constant.

9.6 Adjustable Cable Drop

Compensation

Built-in cable drop compensation is used to get better load regulation. In this way, the voltage at the end of the cable of no load and full load is nearly the same.

In different applications using different cables, we could adjust the resistance of the divider connected to the FB pin. The larger impedance of the cable, the larger divider will be used.

9.7 Protection Control

PL3325C has built-in rich protection features including Cycle-by-Cycle Current Limiting, Power on Soft Start, Under Voltage Lockout on VDD and Open-loop Protection.

PL3325C is shut down when VDD drops below the UVLO (ON) limit and the power converter enters the power on start-up sequence thereafter

10 Packaging Information

SOP7 package

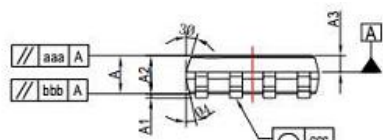

Top View

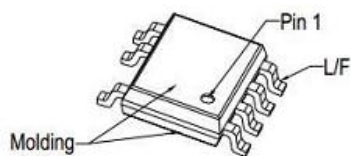

ISO View

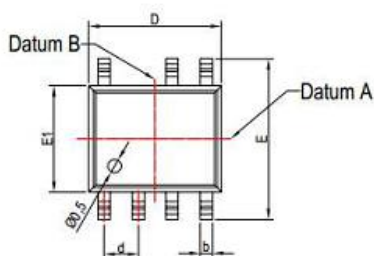

Front View

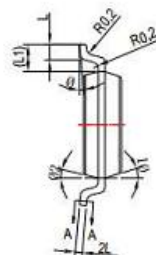

Right View

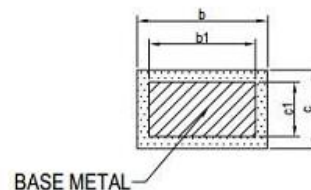

SECTION A-A

Dimensional References unit:mm

Ref.	MIN	NOM	MAX	Ref.	MIN	NOM	MAX
A	1.35	1.55	1.75	E1	3.8	3.9	4.0
A1	0.10	0.15	0.25	L	0.45	0.60	0.80
A2	1.25	1.40	1.65	L1	1.04 REF		
A3	0.5	0.6	0.7	L2	0.25 BSC		
b	0.38	/	0.51	R	0.07	/	/
b1	0.37	0.42	0.47	R1	0.07	/	/
c	0.17	/	0.25	Φ	0°	/	8°
c1	0.17	0.20	0.23	Φ 1	15°	17°	19°
D	4.8	4.9	5.0	Φ 2	11°	13°	15°
d	1.27 BSC			Φ 3	15°	17°	19°
E	5.8	6.0	6.2	Φ 4	11°	13°	15°
aaa	0.10			bbb	0.10		
ccc	0.10						

DIP7

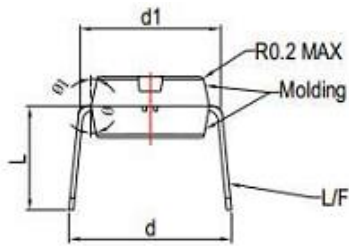

Front View

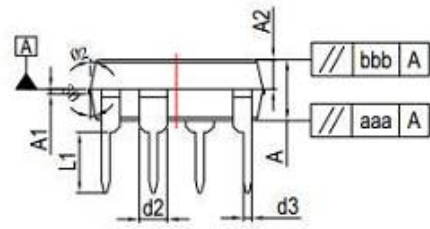

Right View

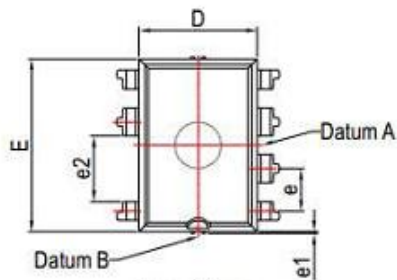

Top View



ISO View

Dimensional References unit:mm

Ref.	MIN	NOM	MAX	Ref.	MIN	NOM	MAX
A	3.224	3.274	3.324	e	2.54 BSC		
A1	0.254 BSC			e1	/	/	0.1
A2	1.54	1.59	1.64	e2	3.556 BSC		
D	6.33	6.38	6.43	L	5.57 REF		
d	8.42	8.72	9.02	L1	3.0	3.3	3.6
d1	7.32	7.62	7.92	Φ	9°	10°	11°
d2	1.524 BSC			$\Phi 1$	11°	12°	13°
d3	0.457 BSC			$\Phi 2$	11°	12°	13°
E	9.2	9.25	9.3	$\Phi 3$	9°	10°	11°
aaa	0.10			bbb	0.10		

SOP8

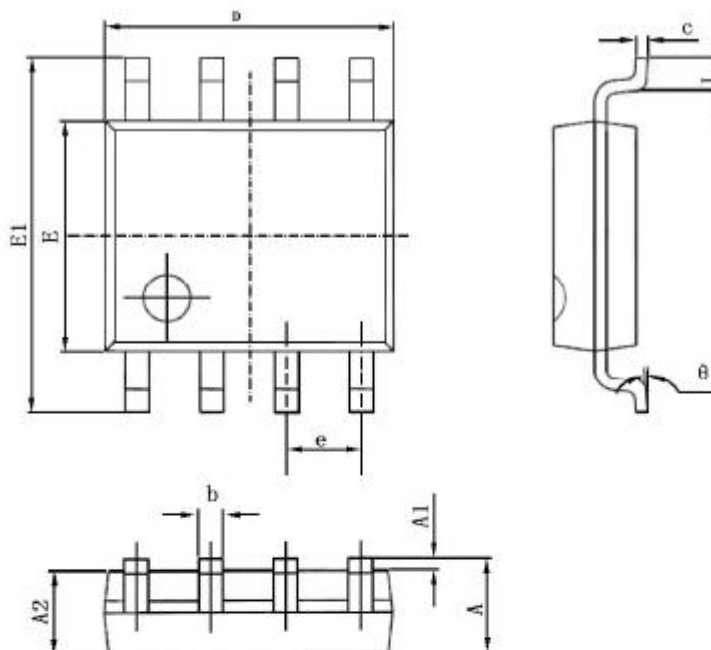

符号	毫米尺寸		英寸尺寸	
	最小	最大	最小	最大
A	1.350	1.750	0.053	0.069
A1	0.050	0.250	0.002	0.010
A2	1.250	1.650	0.049	0.065
b	0.310	0.510	0.012	0.020
c	0.100	0.250	0.004	0.010
D	4.700	5.150	0.185	0.203
E	3.800	4.000	0.150	0.157
E1	5.800	6.200	0.228	0.244
e	1.270(BSC)		0.050(BSC)	
L	0.400	1.270	0.016	0.050
θ	0°	8°	0°	8°

11 Important Notice

POWERLINK reserves the right to make changes or corrections to its products at any time without notice. Customers should verify the datasheets are current and complete before placing orders.